



MZ250



25,10 m



23,10 m



10,35 m (250 kg)
14,35 (80 kg)



250 kg

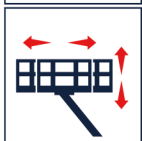

1,40x0,70x1,10 m



90°+90°



400°



EX
Stabilizzatori a estensione
laterale idraulica



3,5 t



MZ250

Iveco PTT=3500kg

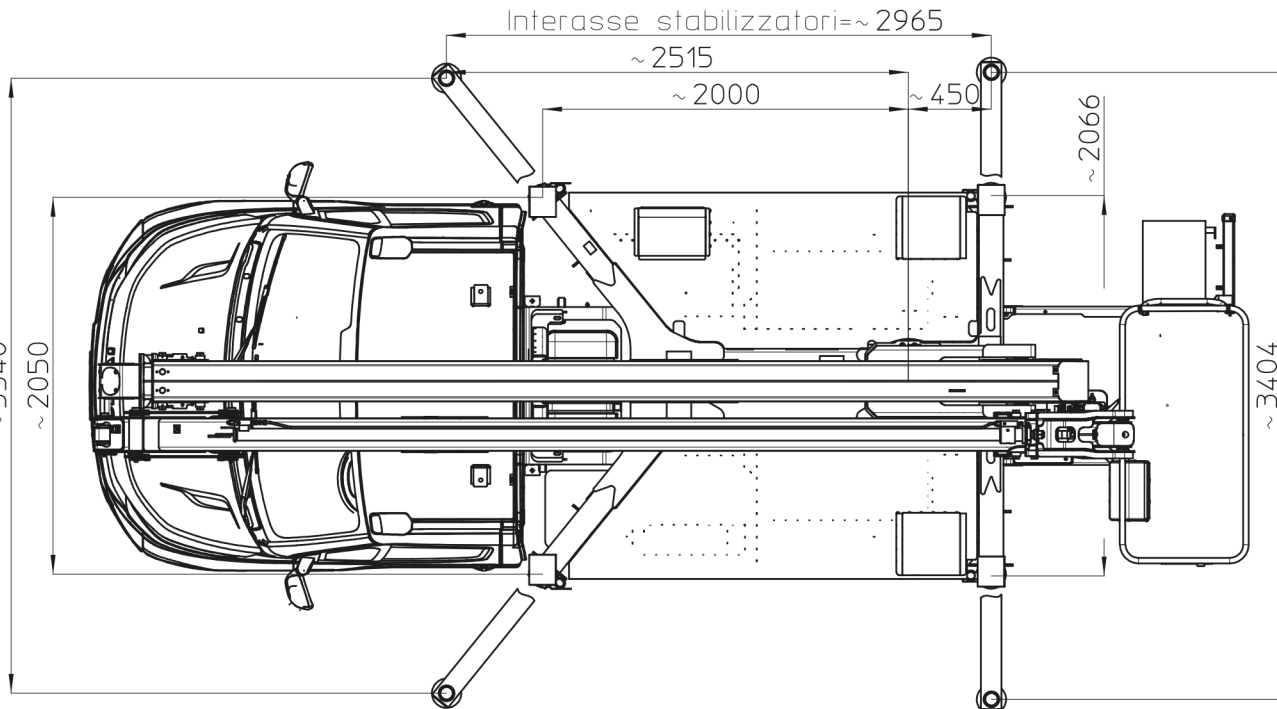
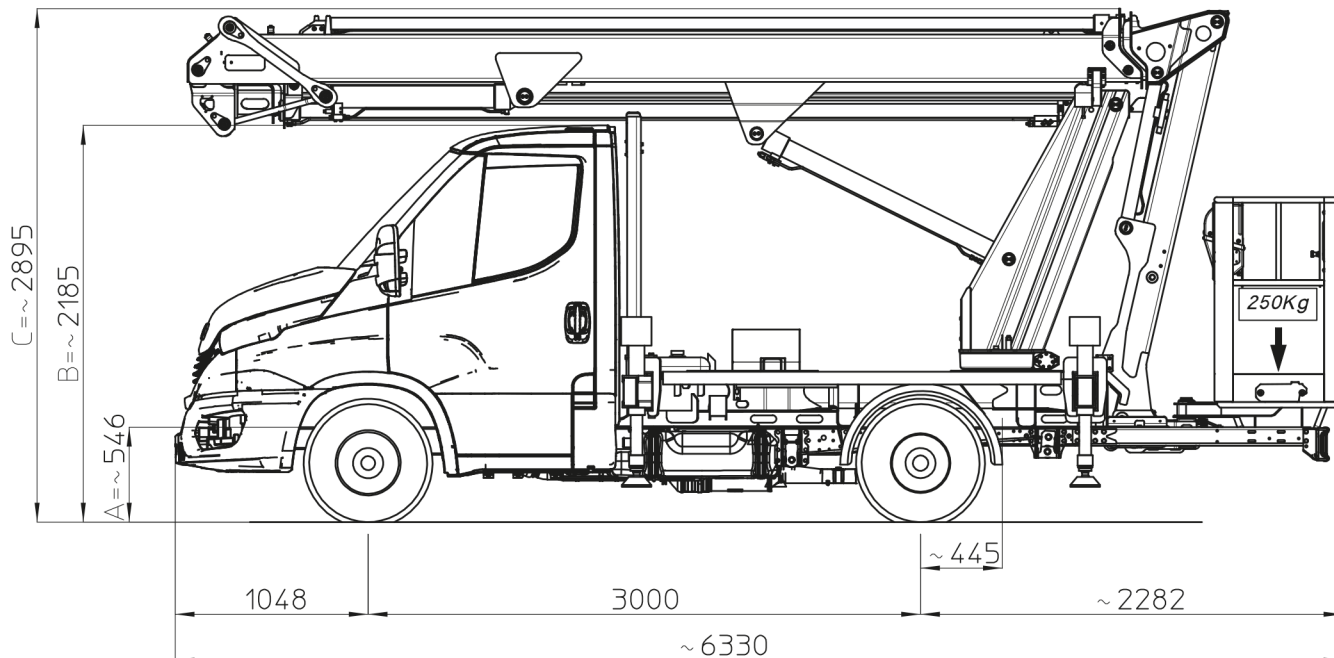

I - Le quote riportate in disegno sono indicative e possono subire variazioni. In particolare le quote A-B sono relative alle dimensioni dell'autocarro, quindi devono essere verificate sullo stesso. La quota C (altezza totale) e' subordinata alle quote A-B e non comprende eventuali parti flessibili.

F - Les cotes indiquées dans le dessin sont indicatives et peuvent subir des variations. En outre les cotes A-B sont relatives aux dimensions du porteur, donc elles doivent être vérifiées sur le porteur même. La cote C (hauteur totale) est subordonnée aux cotes A-B est indiquée hors flexibles.

E - The dimensions shown in the drawing are an indication and may undergo changes. Further the dimensions A-B are related to the truck sizes, therefore they must be verified. The dimension C (total height) is subject to A-B and does not include hoses.

D - Die Maße, die in der Zeichnung gezeigt werden, sind eine Anzeige und können Änderungen durchmachen. Die Abmessungen A-B betreffen die Fahrzeugmasse, daher sollen sie geprüft werden. Die Abmessung C (Gesamthöhe) hängt von A-B Abmessungen ab, die schlauche sind ausgeschlossen.

D67449

Ente	Rev.	Descrizione	Data	Dis.	Contr.	Ap.AQ
MRK	0	EMISSIONE	20/11/19	A.G.		
INGOMBRO - SCHEDA 54/1 - Rev. 0 - 15/12/00						

MZ250

Ente	Rev.	Descrizione	Data	Dis.	Contr.	Ap.A0
MRK	0	EMISSIONE	16/01/19	A.D.		
INGOMBRO - SCHEDA 54/1 - Rev. 0 - 15/12/00						

Iveco Daily 35S12 Euro6

D65835

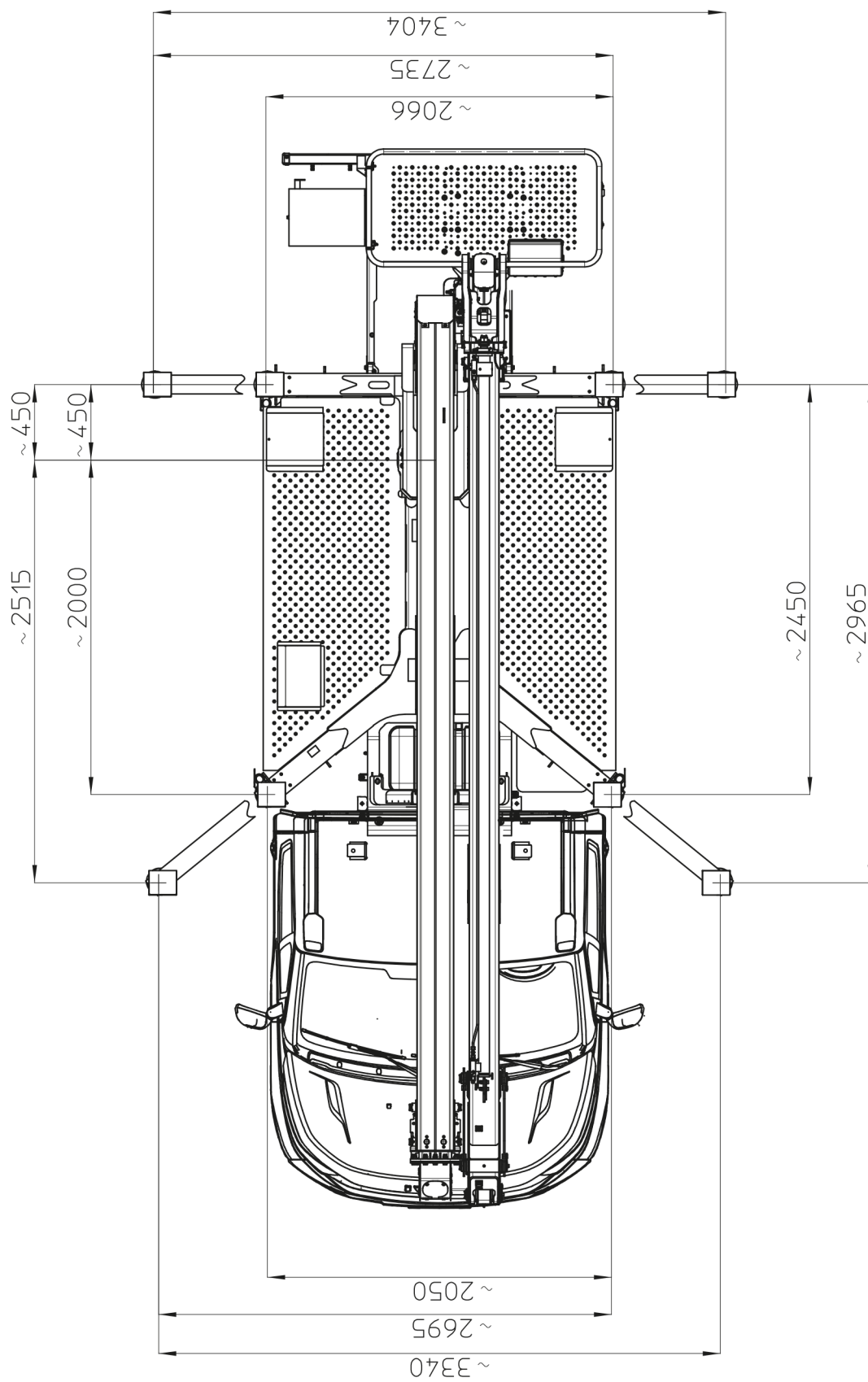

MZ250

Ente	Rev.	Descrizione	Data	Dis.	Contr.	Ap.AQ
MRK	1	EMISSIONE	17/01/19	A.G.		
DIAGRAMMA - SCHEDA 54/2 - Rev. 0 - 15/12/00						

D65837-M

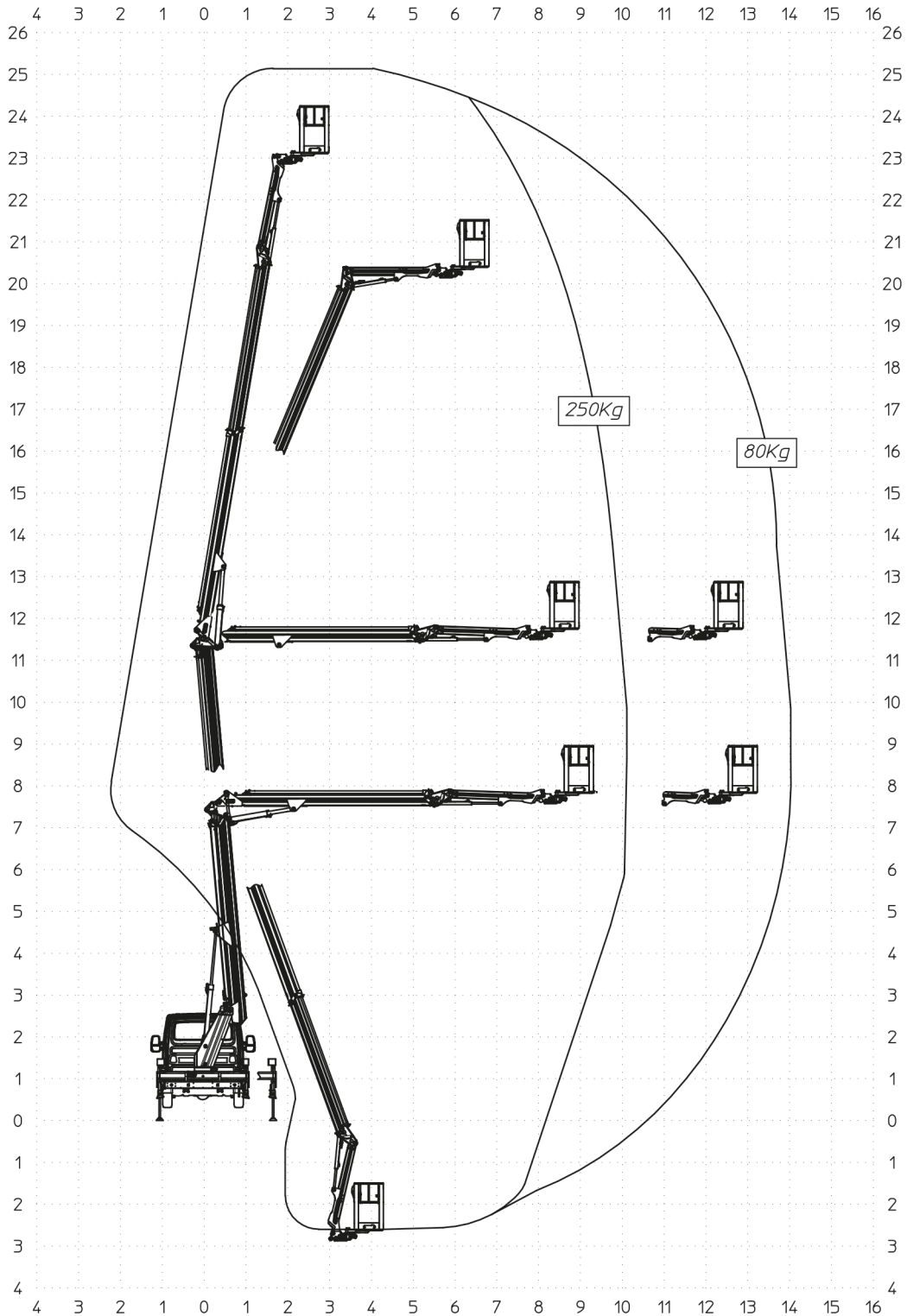

MZ250

Ente	Rev.	Descrizione	Data	Dis.	Contr.	Ap.AQ
MRK	1	EMISSIONE	17/01/19	A.G.		
DIAGRAMMA - SCHEDA 54/2 - Rev. 0 - 15/12/00						

D65839-M

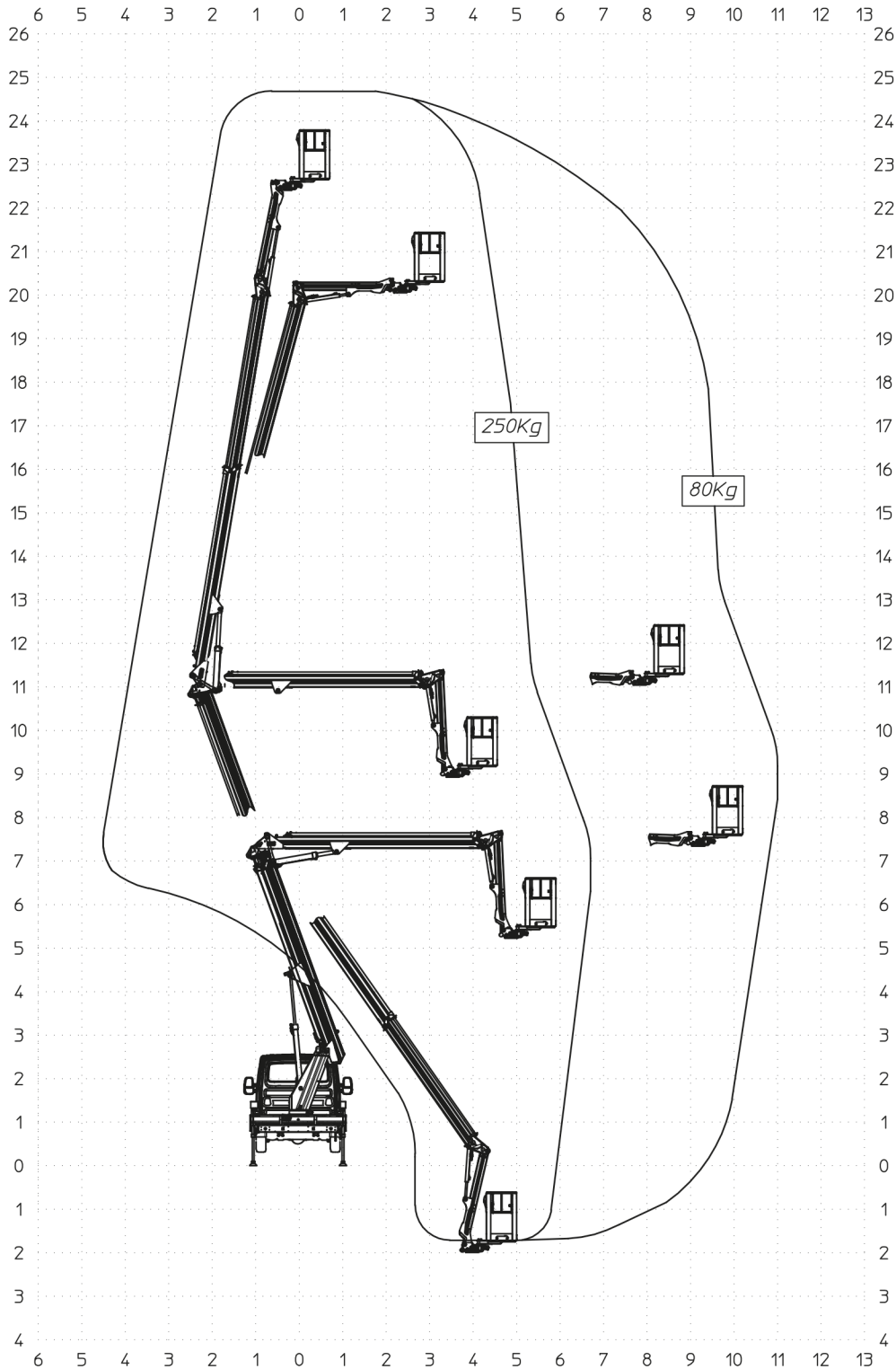

MZ250

Ente	Rev.	Descrizione	Data	Dis.	Contr.	Ap.AQ
MRK	0	EMISSIONE	02/12/20	F.Z.		
DIAGRAMMA - SCHEDA 54/2 - Rev. 0 - 15/12/00						

D68365-M

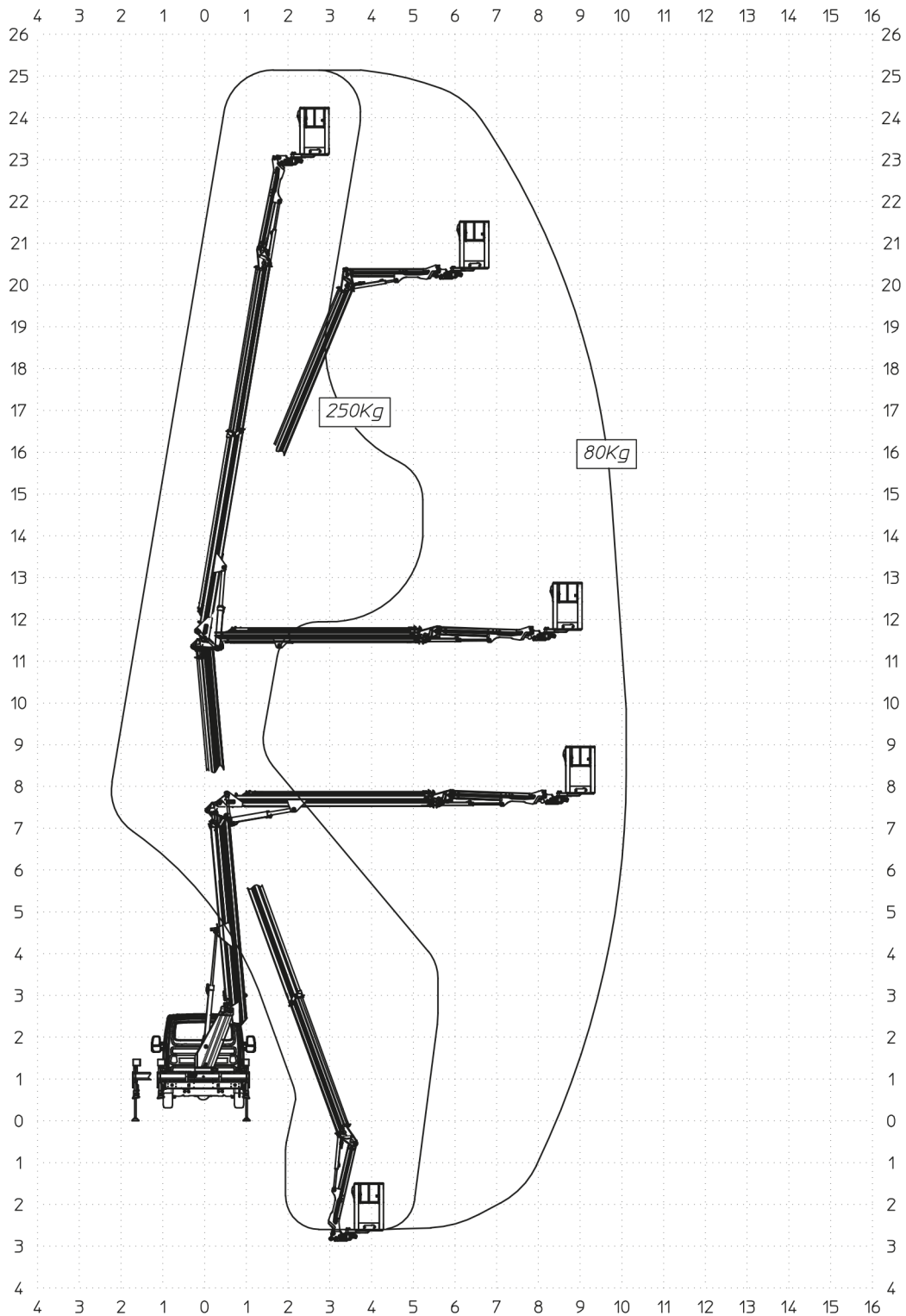

MZ250

Ente	Rev.	Descrizione	Data	Dis.	Contr.	Ap.AQ
MRK	1	EMISSIONE	17/01/19	A.G.		
DIAGRAMMA - SCHEDA 54/2 - Rev. 0 - 15/12/00						

D65838-M

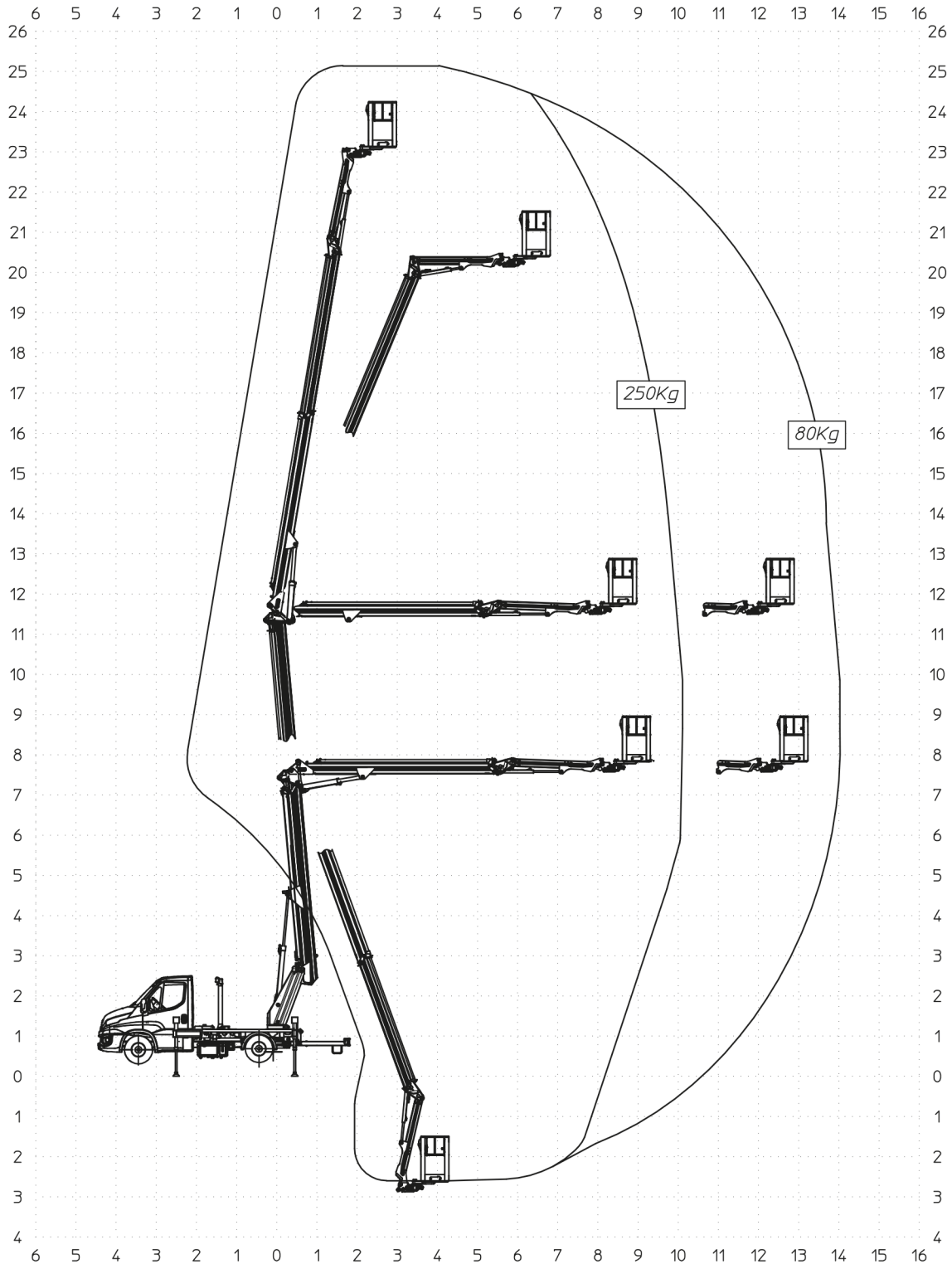

MZ250

Ente	Rev.	Descrizione	Data	Dis.	Contr.	Ap.AQ
MRK	1	EMISSIONE	17/01/19	A.G.		
DIAGRAMMA - SCHEDA 54/2 - Rev. 0 - 15/12/00						

D65840-M

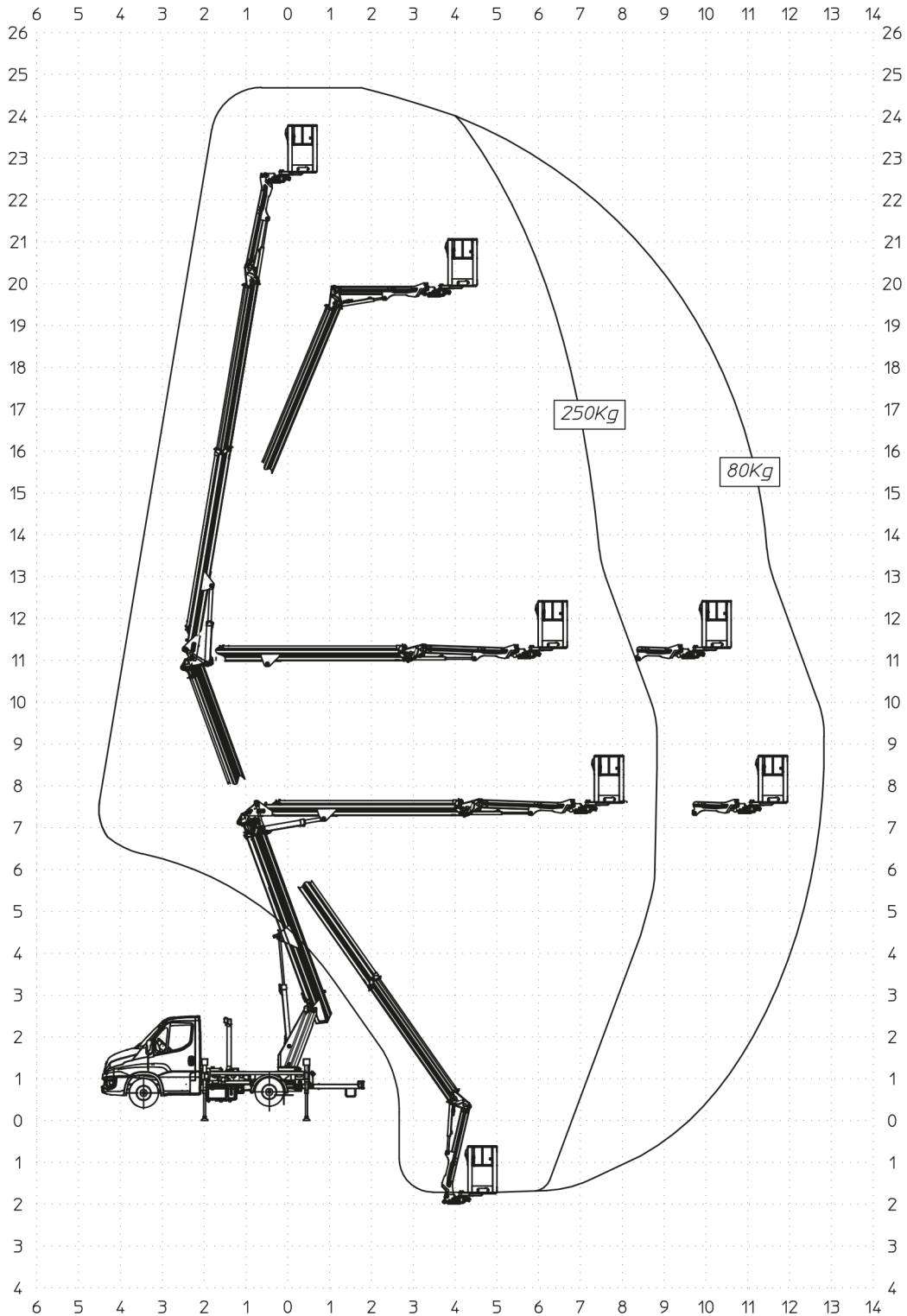

MZ250

Iveco Daily PTT=3500kg

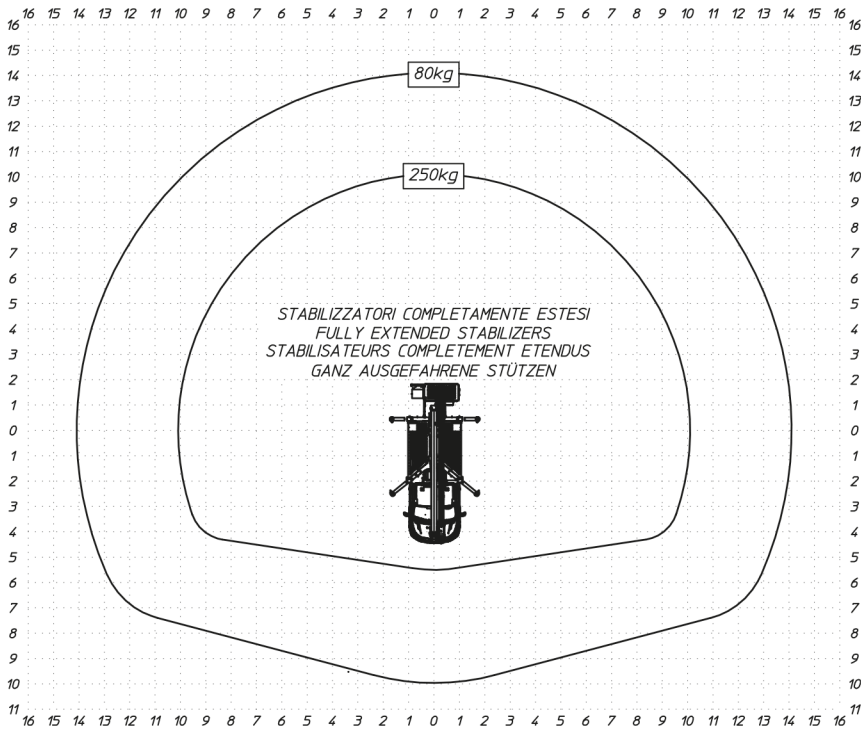
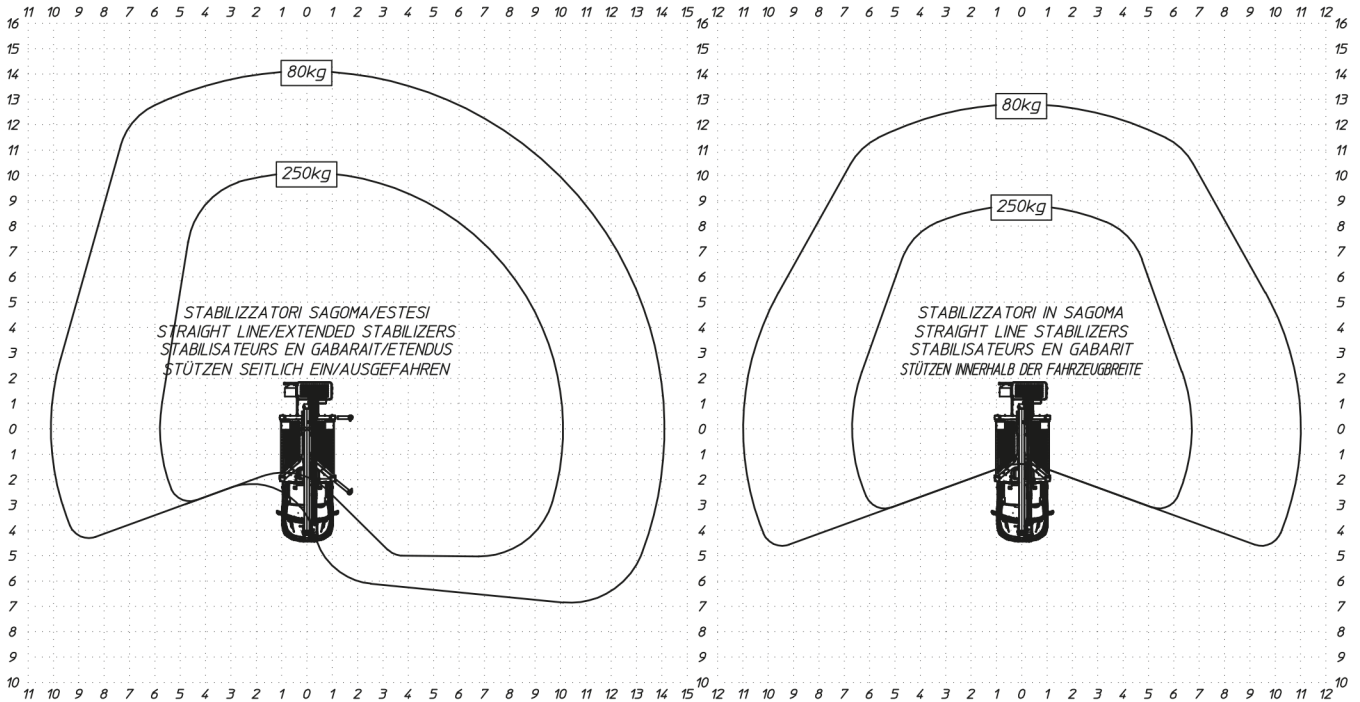

D65836-CE

Ente	Rev.	Descrizione	Data	Dis.	Contr.	Ap.AQ
MRK	2	EMISSIONE	02/12/20	F.Z.		
INGOMBRO - SCHEDA 54/1 - Rev. 0 - 15/12/00						