



MX290



29,30 m



27,30 m

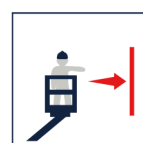

11,70 m (300 kg)
14,80 m (15 kg)



300 kg

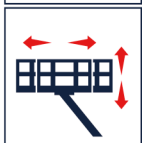

1,70x0,80x1,10 m



90°+90°



400°



EX
Stabilizzatori a estensione
laterale idraulica



7,5 t



MX290

Mitsubishi FUSO Canter PTT=7500kg

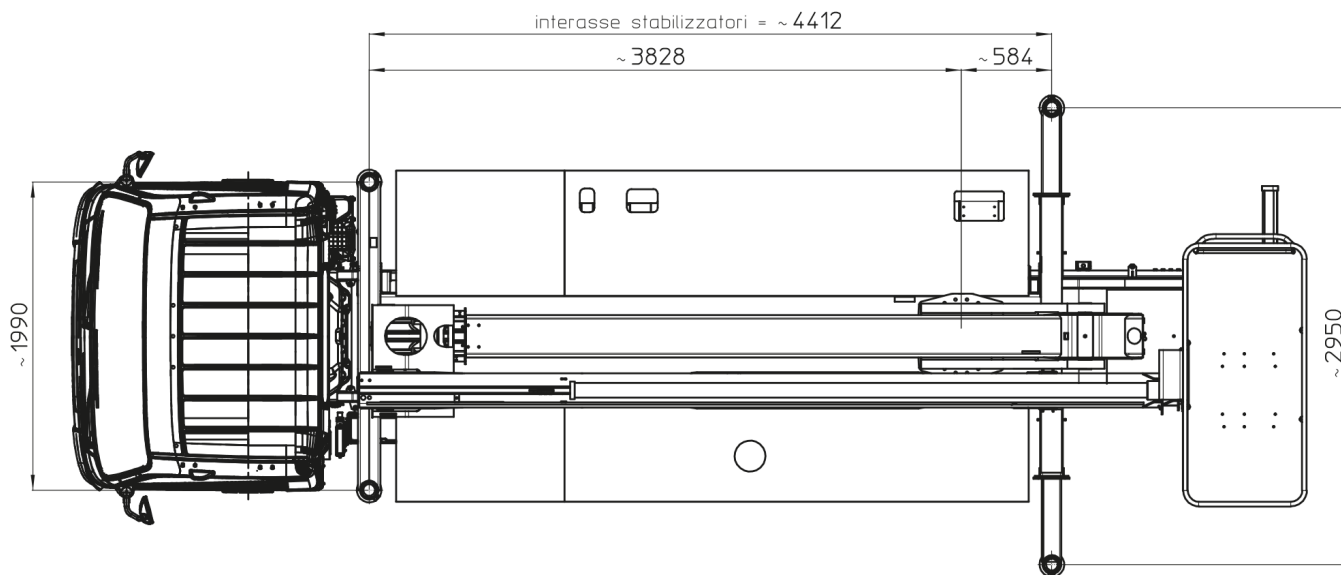
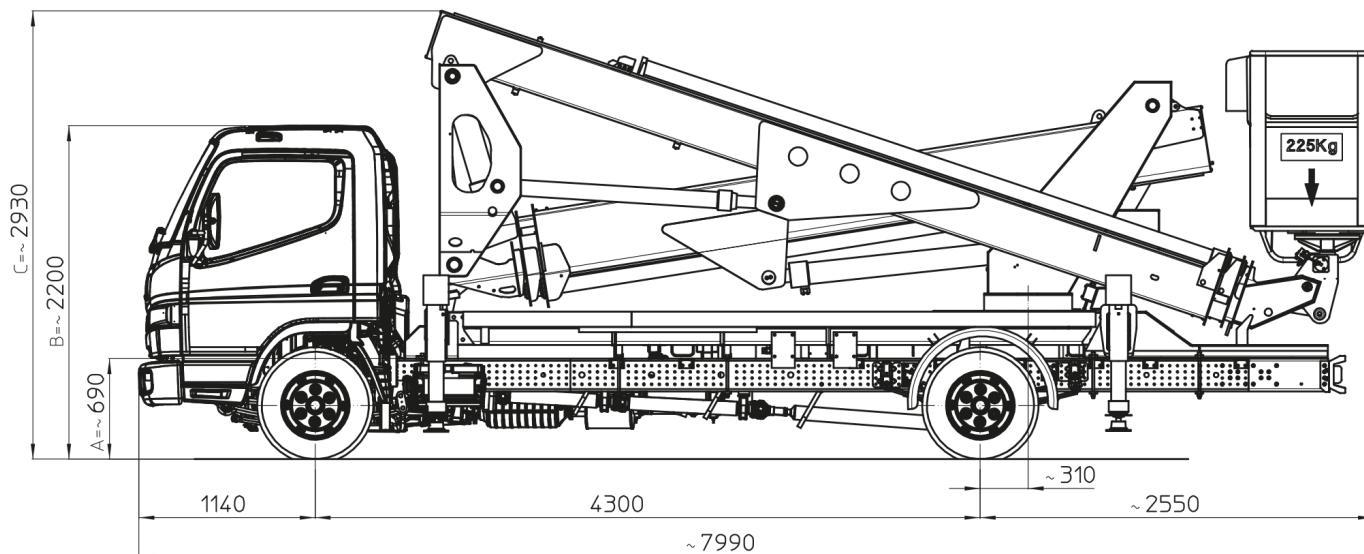

I - Le quote riportate in disegno sono indicative e possono subire variazioni. In particolare le quote A-B sono relative alle dimensioni dell'autocarro, quindi devono essere verificate sullo stesso. La quota C (altezza totale) e' subordinata alle quote A-B e non comprende eventuali parti flessibili.
 F - Les cotes indiquée dans le dessin sont indicatives et peuvent subir des variations. En outre les cotes A-B sont relatives aux dimensions du porteur, donc elles doivent être vérifiées sur le porteur même. La cote C (hauteur totale) est subordonnée aux cotes A-B est indiquée hors flexibles.
 E - The dimensions shown in the drawing are an indication and may undergo changes. Further the dimensions A-B are related to the truck sizes, therefore they must be verified. The dimension C (total height) is subject to A-B and does not include hoses.
 D - Die Maße, die in der Zeichnung gezeigt werden, sind eine Anzeige und können Änderungen durchmachen. Die Abmessungen A-B betreffen die Fahrzeugmasse, daher sollen sie geprüft werden. Die Abmessung C (Gesamthöhe) hängt von A-B Abmessungen ab, die schlauche sind ausgeschlossen.

D50977

Ente	Rev.	Descrizione	Data	Dis.	Contr.	Ap.AQ
MRK	0	EMISSIONE	27/09/13	L.B.		
INGOMBRO - SCHEDA 54/1 - Rev. 0 - 15/12/00						

MX290

D46493-M

Ente	Rev.	Descrizione	Data	Dis.	Contr.	Ap.AQ
MRK	0	EMISSIONE	27/09/13	L.B.		
INGOMBRO - SCHEDA 54/1 - Rev. 0 - 15/12/00						

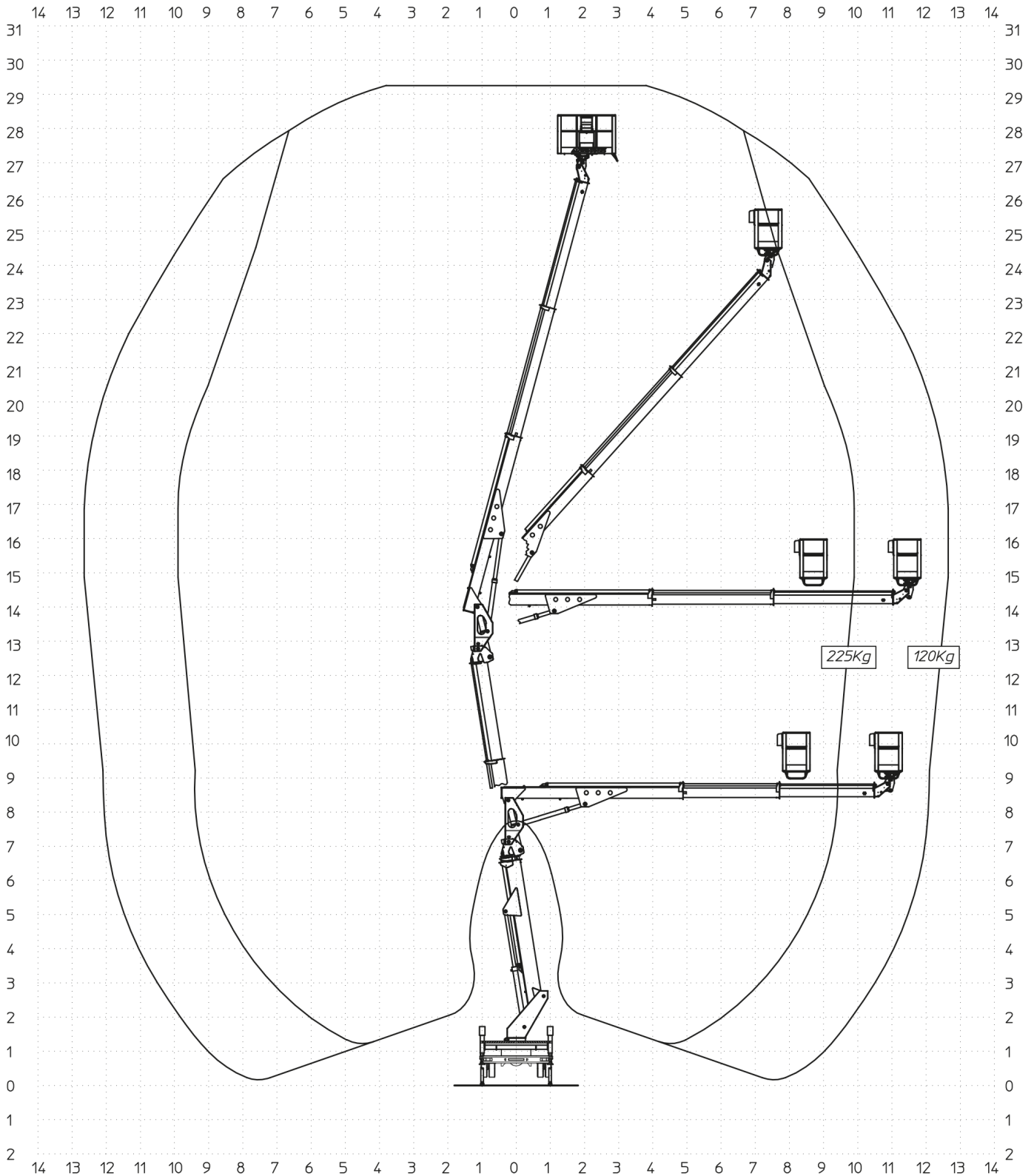

MX290

D46494-M

Ente	Rev.	Descrizione	Data	Dis.	Contr.	Ap.AQ
MRK	0	EMISSIONE	27/09/13	L.B.		
INGOMBRO - SCHEDA 54/1 - Rev. 0 - 15/12/00						

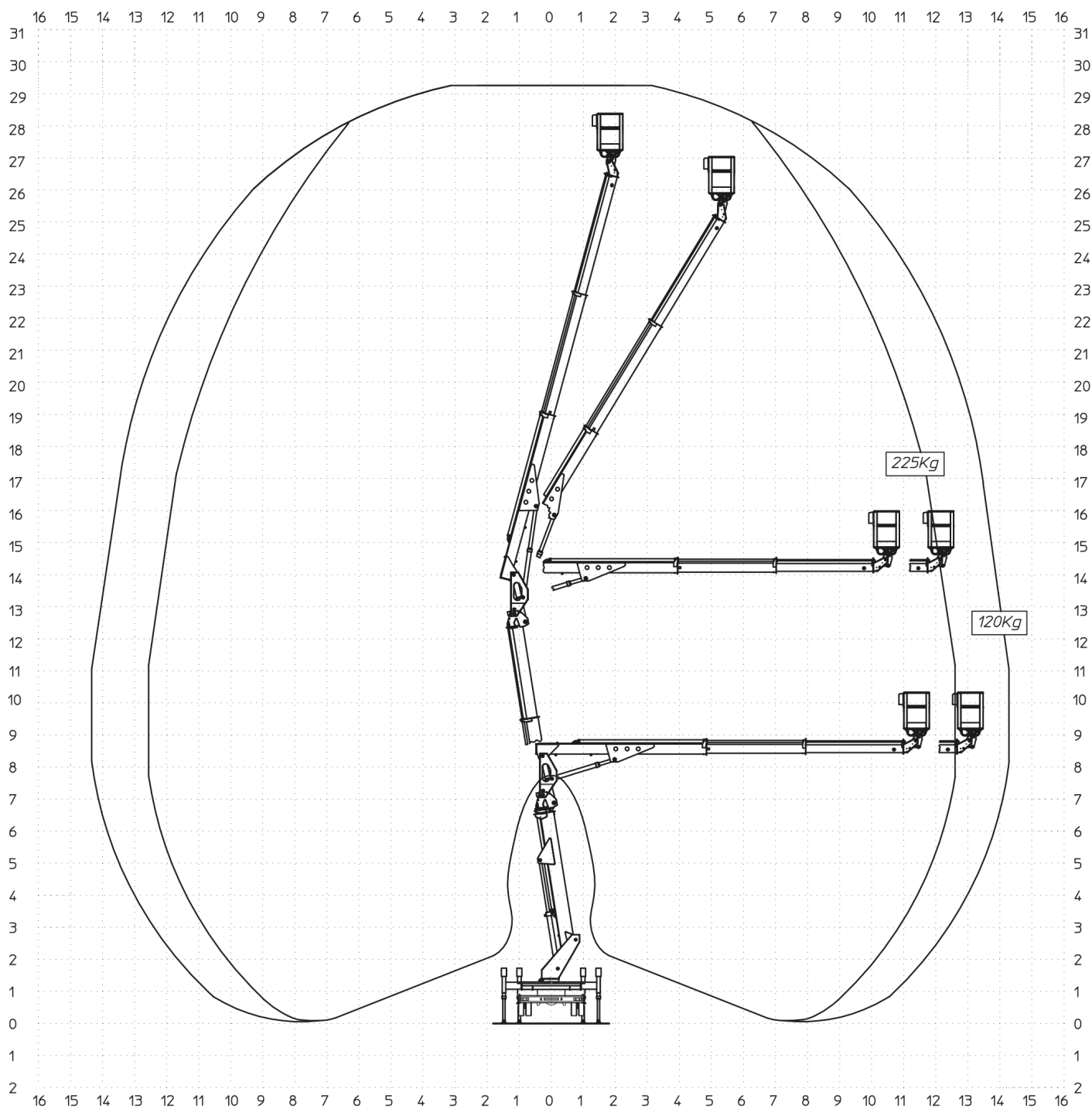

MX290

P.T.T. 7500 kg

STABILIZZATORI
POSTERIORI

REAR
STABILIZERS

STABILISATEURS
ARRIERE

HINTERE
STUTZEN

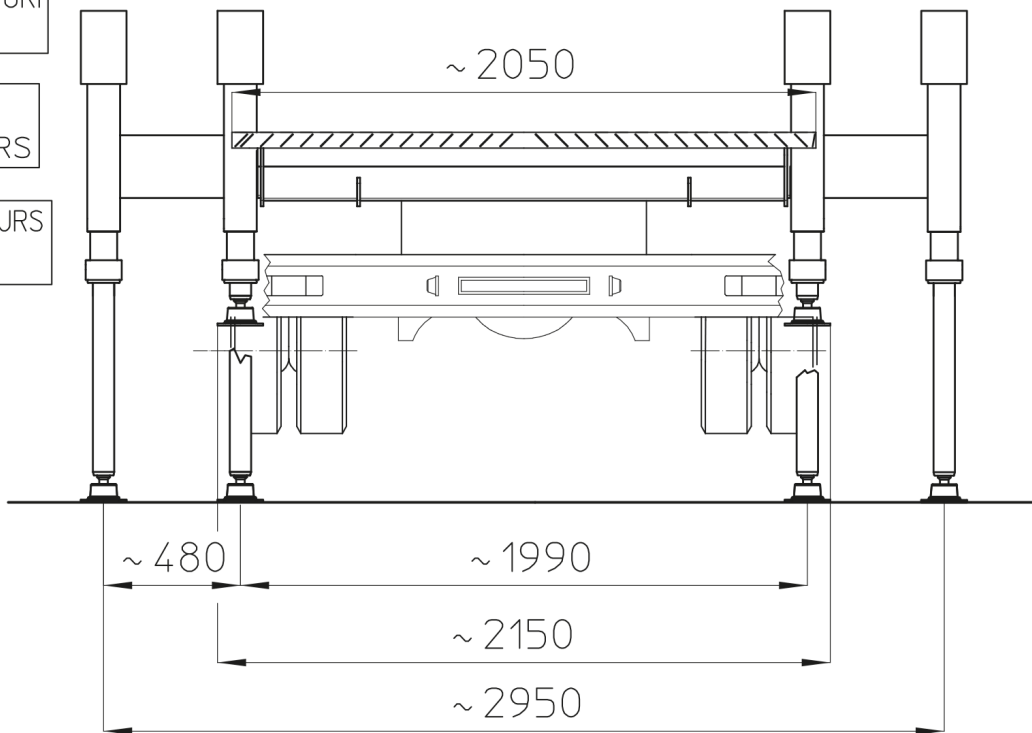

stabilizzatori EX

STABILIZZATORI
ANTERIORI

FRONT
STABILIZERS

STABILISATEURS
AVANT

VORDERE
STUTZEN

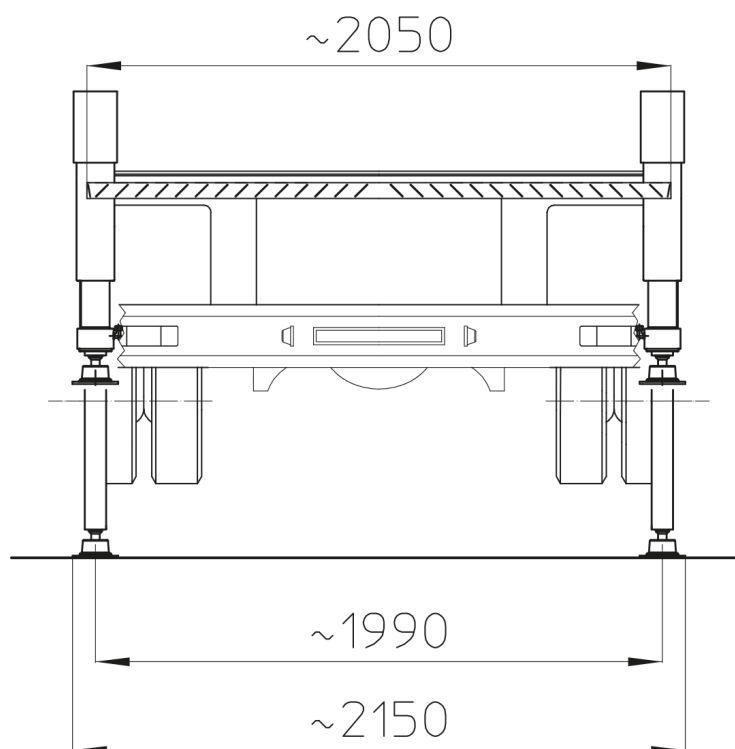

stabilizzatori DS

D46489

Ente	Rev.	Descrizione	Data	Dis.	Contr.	Ap.AQ
MRK	0	EMISSIONE	23-05-11	P.F.		
INGOMBRO - SCHEDA 54/1 - Rev. 0 - 15/12/00						